



TOP TWO IC BRAND

TECHNICAL SUPPORT SERVICES

We are committed to providing you with comprehensive and professional support, services and information. We promise to provide lifetime service before, during and after the use period of the instrument.



Sample testing and application consulting service;

On-site installation and commissioning;

Professional maintenance contract and maintenance service;

Instrument operation training;

Free software upgrade;

Real-time technical support through video, telephone or e-mail;

Localization services by cooperating with local distributors .

Qingdao Shenghan Chromatograph Technology Co., Ltd.

Add: No.151 Zhuzhou Road, Laoshan District, Qingdao, China

Tel: +86-532-68069317

FAX: +86-532-68069838

E-mail: inquiry@qdsrd.com

Web:<https://www.sheng-han.net/>

*Information in this brochure is for reference only. Sales are not binding.
Please consult in detail when ordering. Any changes are not notified. Edition: 1.0.0 EN-2022.12

SHINE



ION CHROMATOGRAPH

Qingdao Shenghan Chromatograph Technology Co.,Ltd



MAKING EFFORTS TO LABEL CHINESE SCIENTIFIC INSTRUMENTS AS TOP-CLASS,
COME TOWARDS THE WORLD AND SERVICE GLOBALLY.

About us

Qingdao Shenghan Chromatograph Technology Co., Ltd. (SHINE) was established in 2002, specializing in the R&D, production, sales and after-sales service of ion chromatograph and relevant parts. It is a high-tech enterprise with ISO 9001 quality management system certification and ISO 24001 environmental management system certification. The total number of independent intellectual property rights, patents and software copyrights belonging to SHINE is about 100.

At present, the company has 4 series of ion chromatograph: desktop IC, portable IC, online IC and customized IC, which are widely used in environmental protection, food and drug, hydrogeology, petrochemical, health and epidemic prevention, electronic and electrical, scientific research and other industries. It basically meets the requirements of routine and trace detection of anion, cyanide, iodide, sugar, small molecular organic acid, etc. At present, it has provided perfect solutions for 5000+ users in different industries and exported to more than 70 countries and regions. In addition, SHINE is one of the few enterprises in the world that can realize mass production of IC columns.

To protect the rights and interests of users, SHINE has set up a powerful after-sales service team with 24-hour free customer service hotline, 8 authorized after-sales service stations in China, and cooperates with foreign local agents to ensure response within 2 hour and relieve users' worries.

Through rapid development, the company has grown in enterprise scale, R & D and market share. It is a highly recognized solution provider for ion chromatography in China.

TYPICAL USER



ION CHROMATOGRAPHY FLOW DIAGRAM

Ion exchange chromatography is a separation technology. The dissociatable ions on ion exchange resin exchange reversibly with the solute ions with the same charge in mobile phase. Ions are separated because of their difference in affinity to ions exchangers. So ion chromatograph is generally applicable to the separation and detection of hydrophilic anions and cations.

After the sample is injected, the ions to be analyzed are exchanged with dissociatable ions on the ion exchange resin at first (i.e. retained on the analytical column). When NaOH solution is used as eluent to analyze F^- , Cl^- and SO_4^{2-} in the sample, the ions retained on the analytical column are replaced by OH^- in the eluent, and the ions with weak affinity to the resin are eluted firstly. This is the separation process of ion chromatography. The eluent is suppressed by a chemical suppressor which can reduce the background conductance of the eluent. Then the ions to be analyzed can be measured accurately when it entered into the conductivity cell, and the detection signal can be outputted.

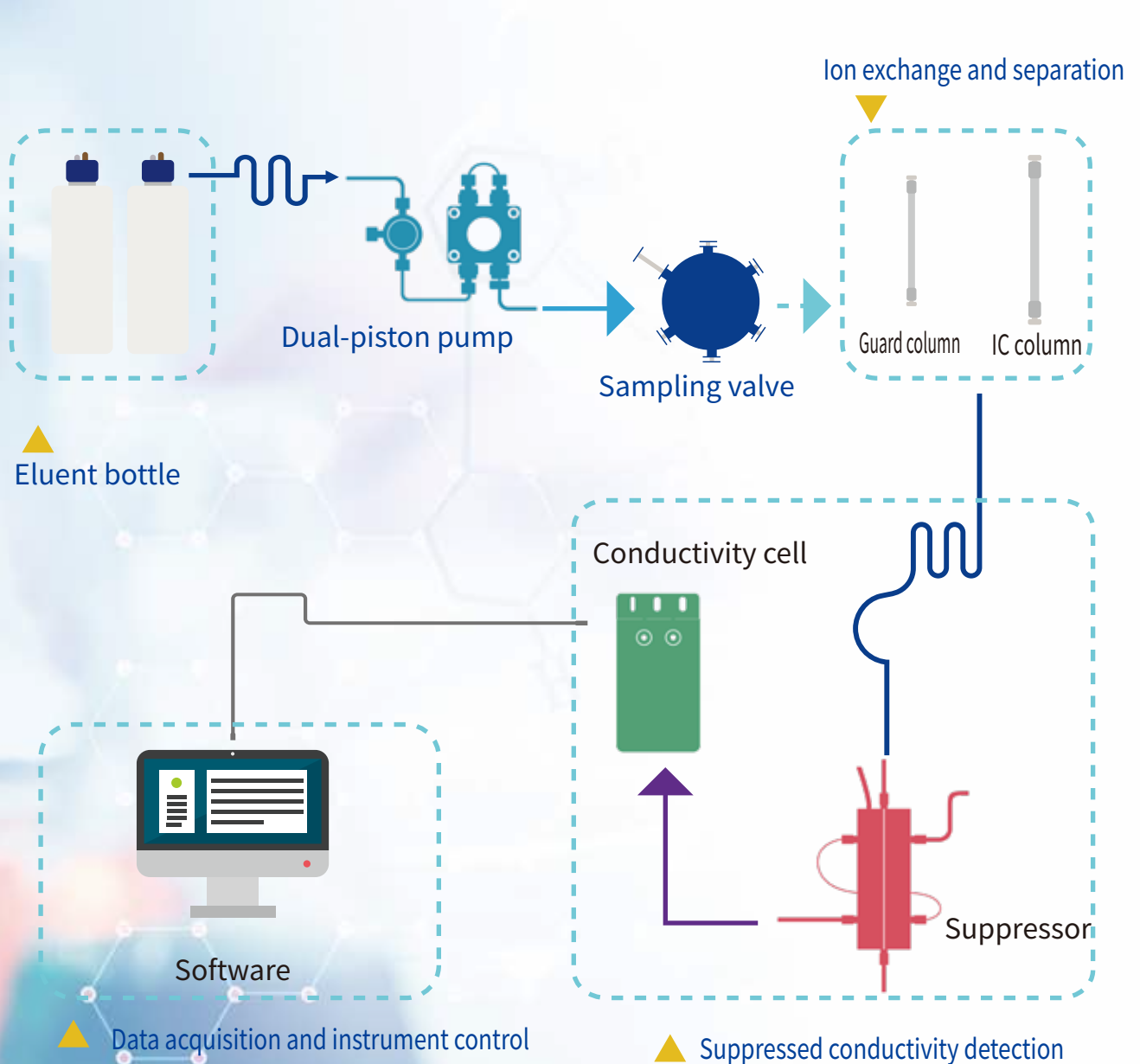

INTERNATIONAL STANDARD

Standard Number	Title of Standard
US EPA 300.0	Determination of inorganic anions: F ⁻ , Cl ⁻ , NO ₂ ⁻ , Br ⁻ , NO ₃ ⁻ , H ₂ PO ₄ ⁻ , SO ₄ ⁻ , ClO ₂ ⁻ , BrO ₃ ⁻ , ClO ₃ ⁻ .
US EPA 300.1	Determination of inorganic anions in drinking water F ⁻ , Cl ⁻ , NO ₂ ⁻ , Br ⁻ , NO ₃ ⁻ , H ₂ PO ₄ ⁻ , SO ₄ ⁻ ; ClO ₂ ⁻ , BrO ₃ ⁻ , ClO ₃ ⁻ .
US EPA 302.0	Determination of BrO ₃ ⁻ in drinking water using two-dimensional ion chromatography with suppressed conductivity detection.
US EPA 314.0	Determination of ClO ₄ ⁻ in drinking water using ion chromatography with suppressed conductivity detection.
US EPA 321.8	Determination of BrO ₃ ⁻ in drinking waters by ion chromatography(IC) inductively coupled plasma - mass spectrometry(ICP-MS).
US EPA 1636	Determination of Cr(VI) by ion chromatography.
US EPA 6860	ClO ₄ ⁻ in water soils and solid wastes using ion chromatography-electrospray ionization-mass spectrometry (IC-ESI-MS or IC-ESI-MS-MS).
US EPA 9056	Determination of inorganic anions by ion chromatography: F ⁻ , Cl ⁻ , NO ₂ ⁻ , Br ⁻ , NO ₃ ⁻ , PO ₄ ⁻ , SO ₄ ⁻ ;:
US EPA 9058	Determination of ClO ₄ ⁻ using ion chromatography with chemical suppression conductivity detection.
US EPA 332.0	Determination of ClO ₄ ⁻ in drinking water by ion chromatography with suppressed conductivity and electrospray ionization-mass spectrometry(IC-EIMS).
US EPA 314.0	Determination of perchlorate in drinking Water
AOAC Official Method 2001.02	Determination of trans-Galactooligosaccharides.(TGOS) in selected food products.
AOAC Official Method 2012.20	Choline in infant formula and adult nutritionals.
AOAC Official Method 995.13	Carbohydrates in soluble (instant) coffee.
AOAC Official Method 996.04	Sugars in cane and beet final molasses.
AOAC Official Method 997.08	Fructans in food products.
AOAC Official Method 2000.11	Polydextrose in foods.
ASTM D5794 – 95 (Reapproved 2008)	Determination of anions in cathodic electrocoat permeates by ion chromatography.
ASTM D2036 – 09	Standard test methods for cyanides in water.
ASTM D 6832 – 08	Determination of hexavalent chromium in workplace air by ion chromatography and spectrophotometric measurement using 1,5-diphenylcarbazine.
ASTM D6919-09	Determination of dissolved alkali and alkaline earth cations(Li ⁺ , Na ⁺ , NH ₄ ⁺ , K ⁺ , Mg ²⁺ , Ca ²⁺) and ammonium in water and wastewater.
IPC-TM-650 2.3.28	Ionic analysis of circuit boards

PRODUCT INTRODUCTION

Our company now has four series of ion chromatograph: desktop IC, portable IC , on-line IC and customized IC.

The new D-series desktop IC has been greatly improved in instrument stability, intelligence, convenience, functional diversity, and play an important role in the detection of common anions, cations and trace ions.

Portable IC can meet the needs of rapid on-site detection of unexpected events. It not only keeps the accuracy of laboratory IC, but also makes up for the application defects of laboratory IC with the characteristics of portability, on-site and rapid detection.

On-line IC perfectly realize on-line pretreatment, automatic sampling, automatic data processing and other functions, which can continuously detect atmospheric and water quality. On-line combustion IC system provides a simple and reliable way for on-line detection of halogen and sulfur in solid and liquid samples, which greatly expands the application field of IC.

Customized IC is to upgrade the original instruments according to customer requirements.

SHINE IC products are widely used in many industries, such as environmental protection, hydrogeology, petroleum, chemical industry, food, pharmacy, health, epidemic prevention, electronics, electricity and scientific research.



Desktop IC



Portable IC



On-line IC

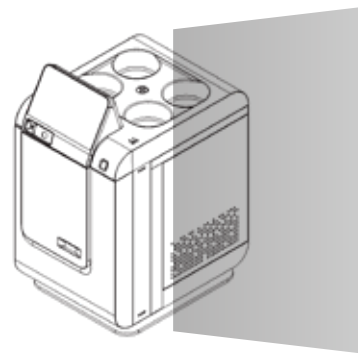

Customized IC

LABORATORY IC

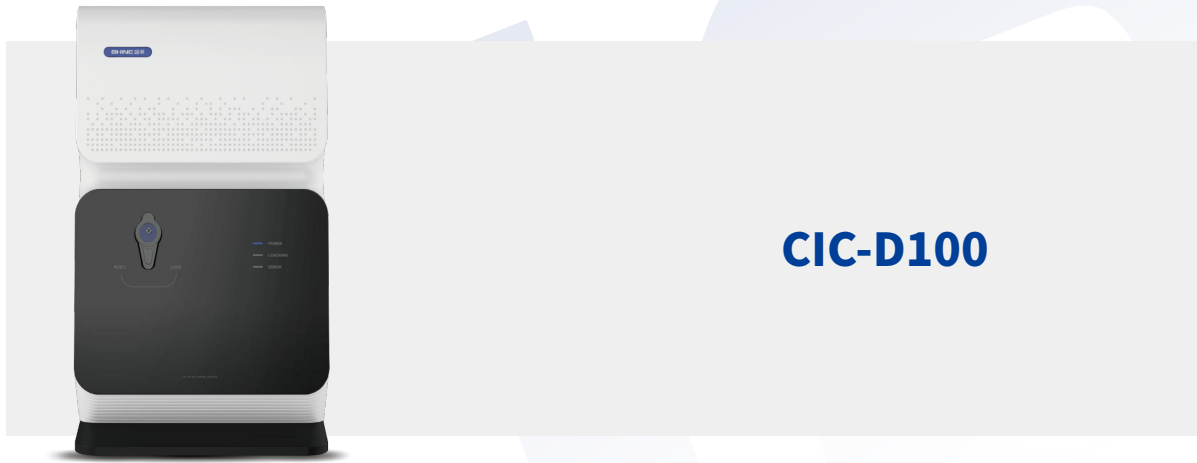

CIC-D100 ion chromatograph is a classic product of SHINE, which has been accepted by many customers. Based on the latest requirements of users, a newly upgraded CIC-D100 for conventional detection came into being. The new IC not only can detect anions, cations and other polar substances in different matrix samples, but also separate ions with 4 orders of magnitude difference. Compared with the previous one, it is more accurate and reliable. One-key switch and intelligent maintenance functions are added to give users a better experience. It is suitable for commercial labs, enterprises, environmental protection, chemical industry, mining & metallurgy, etc.

Highlights:



Built-in circulating 3D constant temperature technology.

Temperature stability time is less than 30 mins, ensuring the accuracy and reliability of test data.



The world's leading full-range series of ion chromatograph columns.

High efficiency, large capacity of the columns for detecting ions of varied compositions.



Self-Regenerating electrolytic micro-membrane suppressor.

High pressure resistance, small dead volume, highly responsive to signals.



Auto-range conductivity detector

It can detect the signal from ppb to ppm without adjusting the range. Only one conductivity detector can detect anions and cations.



Observatory intelligent workstation

Integrated control; With intelligent start-up, shutdown and maintenance functions;- Compatible with a variety of instruments;- Customized images.

LABORATORY IC



CIC-D120+

Highlights:



It has the functions of pressure alarm, liquid leakage alarm and eluent alarm to protect the safe operation of the instrument in real time, alarm and shut down when liquid leakage occurs.



The key components of the suppressor and column have real-time monitoring function to ensure the timely replacement of consumables and ensure the stability and accuracy of the instrument operation.



The gas-liquid separator can effectively remove the influence of bubbles on the test.



LABORATORY IC

CIC-D120+ ion chromatograph is the third generation of SHINE basic intelligent product. The design of the instrument adopts a new concept from appearance to internal structure . It is a fully plasticized reagent-free product, which can be used in many fields such as environmental protection, petrochemical, drinking water, food detection and other conventional and trace detection.



Standard equipped with SHINE high-performance autosampler, more accurate injection control.



The instrument can be started up in advance according to the setting, and the operator can test directly at the unit.



The software has the baseline deduction function and filtering algorithm to effectively remove the baseline drift caused by gradient elution, and the sample response is more obvious.



Auto-range conductivity detector, ppb-ppm concentration range signal is directly expanded, without adjusting the range.

LABORATORY IC



Highlights:



Leakage alarm, the pump will stop automatically after 5 minutes if no treatment.



Auto-range conductivity detector to realize the simultaneous determination of 5ppb-100ppm concentration sample without setting the range.



A micro gas-liquid separator is set to remove the bubble from the eluent.



LABORATORY IC

CIC-D150 ion chromatograph is designed for the intelligentization, which realizes the functions of remote control by mobile APP, timing startup and preheating, one-key intelligent maintenance, etc. it is more convenient to use and greatly improves the productivity and user experience of the laboratory.



By timing startup and preheating function ,users can set the start-up and all parameters of the instrument in advance(the maximum setting time is 24 hours).



Set "intelligent maintenance", the instrument can complete the flow path switch to the pure water path.



The mobile APP can remotely control the instrument on /off and observe the operation performance parameters of the instrument.



The large screen displays the operation parameters and status of the instrument.



LABORATORY IC



CIC-D160+

Highlights:



Built-in eluent generator, which generates eluent of hydroxide or methanesulfonic acid online, can achieve isocratic or gradient elution.



The suppressor and the column have real-time monitoring functions to ensure timely replacement of consumables. It can ensure the stability and accuracy of instrument operation.



The software has a baseline deduction function and filtering algorithm to effectively remove baseline drift and low baseline noise caused by gradient elution.



LABORATORY IC

The CIC-D160+ ion chromatograph is more intelligent, stable, and accurate in performance, and can perform suppression or non suppression conductivity detection. As an upgraded version of CIC-D160, it has a built-in eluent generator. If equipped with an autosampler and ShineLab software, it can achieve 24-hour unmanned injection. At the same time, multiple configuration modes can meet the needs of customers with small sample volumes for single machine use.



It has the functions of pressure alarm, liquid leakage alarm, and washing liquid alarm, which can protect the safe operation of the instrument in real time, and alarm and shut down when liquid leakage occurs.



Auto-range conductivity detector, which directly expands the ppb-ppm concentration range signal without adjusting the range.



Gas-liquid separator, which can effectively remove the impact of bubbles on the test.



The instrument can be started up in advance according to the settings, and the operator can directly test at the unit.

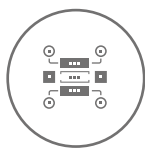

Built-in vacuum degasser to remove bubble interference in the eluent, making testing more stable.

LABORATORY IC



CIC-D180

Highlights:



High definition touch screen can display the flow path and running status of the instrument in real time, operate with one key and view at any time.



The built-in eluent generator generates high-purity KOH and MSA eluent by electrolysis, which saves manual configuration time and completes more detection items by gradient elution.



Built in gas-liquid separation system can filter out the bubbles in the flow path, enhancing the stability.



LABORATORY IC

The simple pipeline layout and various component configurations make CIC-D180 flexible and changeable. It can be equipped with various detectors on demand to realize the combination technology easily. It can also be transformed into dual system and two-dimensional ion chromatograph, which is suitable for various application scenarios.



The intelligent alarm function can recognize the leaks.



Using intelligent detector to detect the residual liquid in the eluent cartridge in real time.



Mobile APP can remotely master every step of analysis in real time, making the work easy and efficient.

LABORATORY IC



CIC-D300 is a kind of ion chromatograph with dual-channel system design. It has stable performance and powerful function. The software realizes the integration of the two-channel workstations, which is easy and fast to operate. One machine can meet the detection requirements of environment, food, chemical industry, electric power, disease control, electronics, mining and metallurgy and other fields.

Highlights:

- Cation and anion dual-channel system, with both channels operating independently without disturbing each other and cations and anions being detected simultaneously;
- Eluent thermal buffer system in which eluent enters into the columns after preheated, to avoid bubbles generated from rapid heating;
- Intelligent flow path mode, one-key operation to complete flow path switch, automatic cleaning to save time and labor;
- Built-in low-pressure degassing technology to eliminate bubble interference for stability;
- The world's leading full-range series of chromatographic columns are able to detect of ions with varied compositions;

LABORATORY IC



CIC-D500+ ion chromatograph, as a new multi-functional ion chromatograph, realizes the modularization of key components such as infusion pump, eluent generator, column oven, conductivity detector, suppressor, etc. The whole machine can be configured optionally. It can not only use conductivity detector, but also use ampere detector or ultraviolet detector at the same time, effectively responding to the needs of high-end customers for multiple detection capabilities of ion chromatograph.

Highlights:

- Two-channel system, two channels operate independently without interference with each other, and can analyze sulfur, iodine, sugar and other components while completing anion/cation detection;
- The dual-channel autosampler can be equipped with three kinds of detectors. In addition to the conventional conductivity detector, it is also equipped with ultraviolet detector and ampere detector, which is more powerful and has a wider detection range;
- Built-in low pressure degassing module can remove the bubble interference in the eluent and make the test more stable;

Intelligent workstation system, with powerful data processing capability and data traceability, is compatible with massive external components.

The eluent generator module can generate anion/cation eluent online to achieve isocratic or gradient elution;

Adapt to the valve switching system of six-way valve and ten-way valve, which can realize online trace detection, and is of great significance for practical detection.

LABORATORY IC



CIC-D300+

Highlights:



10 inch HD touch screen: real time display of flow path and operation status of the instrument.



The built-in eluent generator generates high-purity KOH and MSA eluent by electrolysis, which saves manual configuration time and completes more detection items by gradient elution.



Ultra pure online purification module: it can purify water online and reduce the water requirements of the instrument, so as to reduce the baseline background and improve the signal-to-noise ratio.



LABORATORY IC

CIC-D300+ is a new generation of intelligent dual-channel ionchromatograph. Each channel of it operates independently at the same time without mutual interference, realizing the simultaneous detection of cation and anion.



Suction sampling system: use peristaltic pump to suck samples to reduce cross pollution at the injection port;



The gas-liquid separator will remove most of bubbles entering the flow path, and the constant pressure and low pressure degasser will continuously remove the residual gas dissolved in water.



In the heating degassing unit, there is an integrated on-line vacuum chamber, which can remove the gas in the eluent on-line to make the experimental results more accurate.



Powerful safety assurance system: including eluent consumption alarm, liquid leakage alarm, low pressure alarm, overpressure alarm, fault alarm to reduce possible hurt by misoperation.



CIC-P80 Portable Ion Chromatograph

The portable ion chromatograph is a portable instrument suitable for laboratory and on-site multi-scene detection. It is small in size and light in weight. The whole body is fixed in the three-prevention box (waterproof, anti-corrosion and dustproof) for easy carrying; The water and electricity separation design can effectively prevent the circuit from being damaged due to the leakage of the eluent, and greatly improve the safety and reliability of the instrument; The concept of uninterruptible power supply can ensure that the instrument will not be troubled by the battery power and give customers the ultimate use experience. This instrument, combined with Shinelab intelligent workstation developed by SHINE, can not only test the intelligent control of various functional parts of the instrument, but also has powerful data processing function.

Highlights:

- Be able to adapt to multiple application scenarios.
- The water and electricity separation design can effectively prevent the circuit from being damaged due to the leakage of washing liquid.
- The concept of uninterrupted power supply allows the instrument to replace the standby battery without power failure during operation, which can ensure that the instrument is not troubled by battery power.
- The database language workstation can realize the instrument control, data acquisition and processing under the same interface, and the data security is guaranteed. The Bluetooth printer can also be selected to print the report on site. The instrument is equipped with Bluetooth mouse and keyboard as standard, which is convenient for users to use
- It can be equipped with a portable eluent generator to realize gradient elution, or a portable autosampler. Inhalation sampling design: it can greatly reduce the pollution caused by the traditional injection port and the incomplete cleaning of the syringe, and also reduce the amount of syringe. Users no longer need to carry a large number of syringes to the site, reduce the generation of test waste, and comply with the concept of green chemistry.



SH-GIC7000 On-line Atmosphere Ion Chromatograph

SH-GIC7000 is a full-automatic and intelligent on-line IC for atmosphere, which can detect anions and cations in TSP, PM2.5, PM10 and dustfall to meet the testing requirements of HJ799-2016 and HJ800-2016. The instrument runs continuously for 24 hours and can work continuously for 20 days after one maintenance.

Full plasticized flow system, dual suppression mode, all-weather continuous operation, remote control, remote data transmission and so on make the IC has perfect and advanced solution ability, which brings automatic, intelligent and humanized instrument application experience to users.

Highlights:

- Anions and cations in particulate matter or gas samples can be simultaneously detected by anion-cation dual-channel method;
- Various sampling methods and modes can be selected to meet the requirements of gas and particulate matter samples with different particle sizes;
- Automatic data correction function, testing standard calibration curve regularly, to ensure the accuracy and effectiveness of test data;
- The instrument is equipped with thermostatic column oven and highly sensitive bipolar conductivity detector to make data stable and reliable;
- Special intelligent chromatographic software, icon operation interface, parameter setting and data observation are intuitive and convenient, real-time state monitoring in operation, accurate and reliable data processing;
- Automatic maintenance of equipment, regular self-check of equipment status, automatic cleaning;
- Remote data transmission can connect the network by wireless/wired way, upload the data to headquarters or server for backup and storage;
- Real-time recording of environmental temperature and humidity information makes traceability work has more auxiliary information.



SH-WIC5000 On-line Water Quality Ion Chromatograph

SH-WIC5000 is a full-automatic and intelligent on-line water quality IC, which can realize real-time detection of anions and cations in water samples. The equipment removes organic impurities and solid particles from the samples to be measured by on-line pretreatment system, achieving the functions of continuous automatic sampling, sample pretreatment and data processing, and continuously uploads real-time monitoring data to headquarters or servers in 24 hours.

Full plasticized flow system, dual suppression mode, all-weather continuous operation, remote control, remote data transmission and so on, make the on-line water quality IC has perfect and advanced solution ability. The equipment can provide a complete solutions for the monitoring of inorganic anions and cations in water samples such as tap water, surface water, circulating water of power plants and water for enterprise production.

Highlights:

- Anions and cations can be simultaneously detected by anion-cation dual-channel method;
- Automatic data correction function, testing standard calibration curve regularly, to ensure the accuracy and effectiveness of test data;
- The instrument is equipped with thermostatic column oven and highly sensitive bipolar conductivity detector to make data stable and reliable;
- Special intelligent chromatographic software, icon operation interface, parameter setting and data observation are intuitive and convenient, real-time state monitoring in operation, accurate and reliable data processing;
- Automatic maintenance of equipment, regular self-check of equipment status, automatic cleaning;
- Remote data transmission can connect the network by wireless/wired way, upload the data to headquarters or server for backup and storage.



CIC-3200 On-line Combustion Ion Chromatograph

CIC-3200 on-line combustion ion chromatograph is composed of four modules: autosampler, combustion unit, absorption unit and ion chromatography. The system is completely designed and manufactured by SHINE. It has the characteristics of high intelligence, humanized instrument design, simple software operation, easy learning and high cost performance. It fully meets the needs of users in universities, research institutes, electronic and electrical, electronic materials, non-ferrous metals, mining and metallurgy, nuclear systems, geology and other fields.

Highlightse:

- Automatic sampling: 23-position disc automatic sampler, easy to use and excellent reliability; The cup type sampling boat is more convenient for adding samples, which can effectively avoid accidents such as gas blowing into the combustion tube;
- Automatic sample retention: there is a disc-type automatic sample retention device on the top of the absorption unit, which corresponds to the position of the sample injector one by one. After absorption, the sample will be automatically sucked into the sample retention bottle to meet the requirements of retest and traceability;
- Oxygen purging design: the front of the combustion pipe is equipped with purging oxygen pipeline, which can blow the unburned ash back to the combustion area to ensure full combustion;
- Enrichment function: it can connect the enrichment column to enrich the ions to be tested and improve the accuracy of the detection results;
- Base elimination: can effectively eliminate the interference of hydrogen peroxide base for analysis;
- Peltier cooling module: the minimum temperature can reach 5 °C, which can fully cool the high-temperature gas and increase the absorption efficiency.



Qingdao Shenghan Chromatograph Technology Co., Ltd. has been developing ion chromatographic column since 2008. As the only enterprise in China which can realize mass production of IC columns, SHINE breaks the monopoly of foreign countries. Professional R&D team and advanced production technology ensure that you can get IC columns with good reproducibility and separation effect at any time.

SH series ion chromatographic column

- 01. The first choice for developing or improving IC methods;
- 02. Excellent performance and stable polymer stationary phase;
- 03. Complete batch tracking and reproducibility;
- 04. The only mass-produced IC column in China;
- 05. It has wide applicability and can be widely applied to domestic and imported brand IC.



Suppressor

Suppressor produces H⁺ and OH⁻ through electrolysis of water at the electrode, and under the combined action of electric field and ion exchange membrane, can realize the directional migration and exchange of ions. It reduces the background conductance, improves the sensitivity of ions to be measured, and makes the "counter ion" in the sample enter the waste liquid.



Eluent Generator

The double membrane eluent generator can produce high-purity KOH and MSA eluent by electrolysis, which saves the manual configuration time, the degassing pipe and capture column are not required, the pressure resistance can reach 30MPa, the flow path is simpler and the dead volume is smaller. At the same time, it can realize the gradient elution and separation operation of complex samples which can not be completed by the isocratic pump, which further improves the accuracy of the analysis.



Amperometric Detector

In the case of applied voltage, the amperometric detector detects the change of current caused by the redox reaction of the substance to be measured on the electrode surface. Amperometric detector is often used to analyse ions with low dissociation, which are difficult to detect with conductivity detectors and have electrical activity.



Ultraviolet Detector

The SHUV-10 ultraviolet detector adopts high-speed signal processing technology, has high sampling rate and excellent resolution, advanced optical path design, multi-color filter and grating, and the test wavelength is more stable, ensuring a better linear range. The wavelength is easy to disassemble, clean and maintain the flow cell, effectively extending the service life of the detector.



Autosampler



SHA-9 Single channel



SHA-18 Single/Dual channel



SHA-16 Single /Dual channel

On-line Degasser



SHT-5 is an on-line degasser that can realize multi-channel degassing. It adopts continuous vacuum pumping mode, and the degassing efficiency is more continuous and stable. It can be used for online degassing of mobile phase of liquid chromatograph, ion chromatograph and other equipment. It can meet the expansion requirements of four channels, and the intelligent screen can display the instrument parameters and performance status in real time.

Ultra-pure Ion Purifier



The ultra-pure ion purifier combines electro dialysis technology, ion exchange technology and high ion exchange cycle technology to ensure the consistency of instrument water, so as to achieve the purpose of online water purification.

It reduces the baseline background, improves the signal-to-noise ratio, and reduces the requirements for instrument water;

RO water can be used as water for ion chromatograph to meet the detection requirements for ultra-trace ions in semiconductor, nuclear power and thermal power fields.



INDUSTRY APPLICATION SOLUTIONS



I .Application of Ion Chromatography in Food Safety Analysis

1. Nitrate and nitrite in food

The samples are pretreated according to GB/T 5009.33, and after protein precipitation and fat removal, the samples are extracted and purified by corresponding methods. Using CIC-D180 ion chromatograph ,SH-AC-11 anion column, 15.0 mM NaOH eluent and bipolar pulse conductance method,under the recommended chromatographic conditions, the chromatogram is as follows.

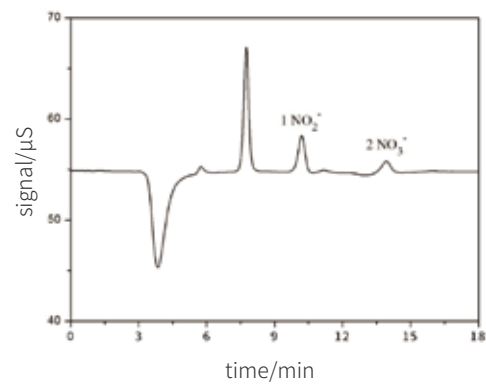

2. Iodide and thiocyanate in dairy products

The milk powder samples are dissolved, mixed with 3% acetic acid and deionized water, filtered by 0.22µm microporous filter membrane and treated by IC-RP column. Using CIC-D180 ion chromatograph, SH-AC-11 anion column, 30 mM NaOH eluent and bipolar pulse conductance method, under the recommended chromatographic conditions, the chromatogram is as follows.

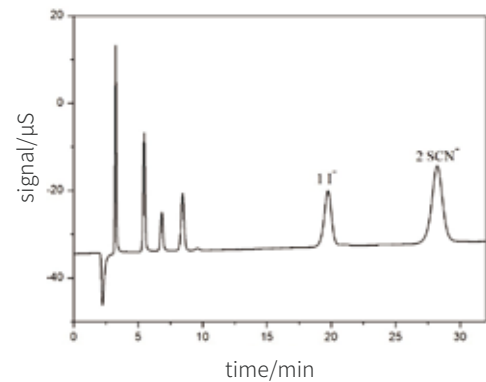

INDUSTRY APPLICATION SOLUTIONS |

II . Application of Ion Chromatography in Drinking Water Analysis

1. Detection of anions in drinking water

The samples are filtered by 0.22µm microporous filter membrane or centrifuged . Using CIC-D150 ion chromatograph, SH-AC-3 anion column, 2.0 mM Na₂CO₃/8.0 mM NaHCO₃ eluent and bipolar pulse conductance method,under the recommended chromatographic conditions, the chromatogram is as follows.

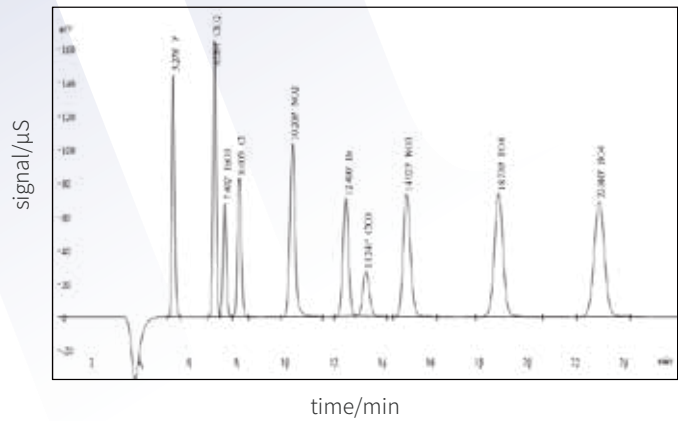

2. Determination of Perchlorate in Drinking Water (EPA 314.0)

Using CIC-D180 ion chromatograph, SH-AP-1 anion column, 35mmol/mL NaOH eluent ,under the recommended chromatographic conditions,the chromatogram is as follows.

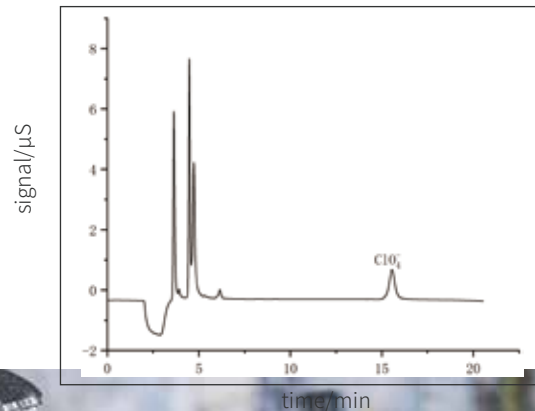

III. Application of Ion Chromatography in Environmental Analysis

1. Detection of common anions in surface water

Surface water is generally relatively clean. After 30 minutes of natural precipitation, taking the non precipitation part of the upper layer for analysis. If there are many suspended substances in the water sample or the color is darker, pretreat it by centrifugation, filtration or steam distillation. Using CIC-D150 ion chromatograph, SH-AC-3 anion column, 3.6 mM Na₂CO₃+ 4.5 mM NaHCO₃ eluent and bipolar pulse conductance method, under the recommended chromatographic conditions, the chromatogram is as follows.

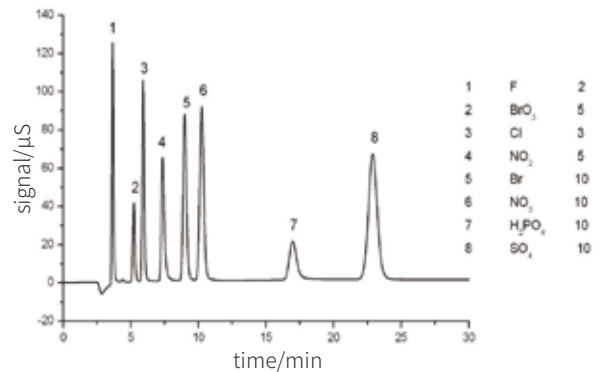

2. Analysis of particulates in atmosphere

The environmental samples of a certain volume or time are collected according to the sampling requirements of TSP, PM10, natural dust and dust storms in the atmosphere. A quarter of the filter membrane samples collected are accurately cut into plastic bottles, adding 20mL deionized water, then volumed to 50mL after being extracted in the ultrasonic cleaner and filtered by a 0.22µm microporous filter membrane. After all this, the sample can be injected for analysis. Using CIC-D150 ion chromatograph, SH-AC-3 anion column, 3.6 mM Na₂CO₃+4.5 mM NaHCO₃ eluent and bipolar pulse conductance method, under the recommended chromatographic conditions, the chromatogram is as follows.

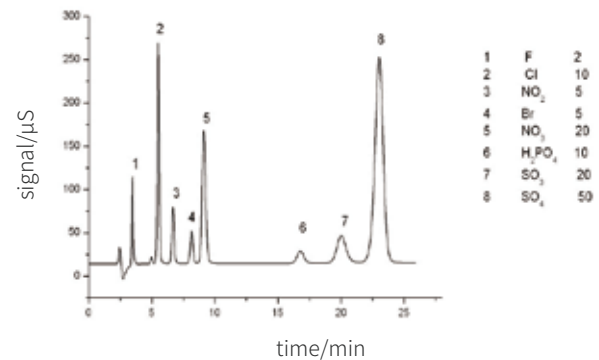

Using CIC-D150 ion chromatograph, SH-CC-3 cation column, 5.5 mM MSA eluent and bipolar pulse conductance method, under the recommended chromatographic conditions, the chromatogram is as follows.

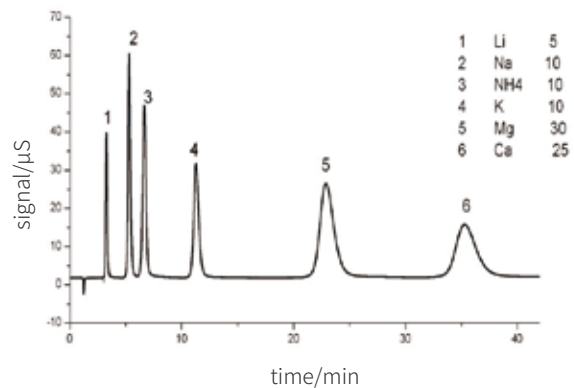

INDUSTRY APPLICATION SOLUTIONS |

IV. Application of Ion Chromatography in Petrochemical Analysis

1. Anion analysis in oil field waste water

Choosing appropriate dilution ratio to dilute oil field waste water, the diluent was filtered by 0.22 μm microporous membrane and treated by IC-RP column. If the sample contains heavy metal and transition metal ions, it must be treated by IC-Na column. Using CIC-D150 ion chromatograph, SH-AC-3 anion column, 3.6 mM $\text{Na}_2\text{CO}_3 + 4.5 \text{ mM NaHCO}_3$ eluent and bipolar pulse conductance method, under the recommended chromatographic conditions, the chromatogram is as follows.

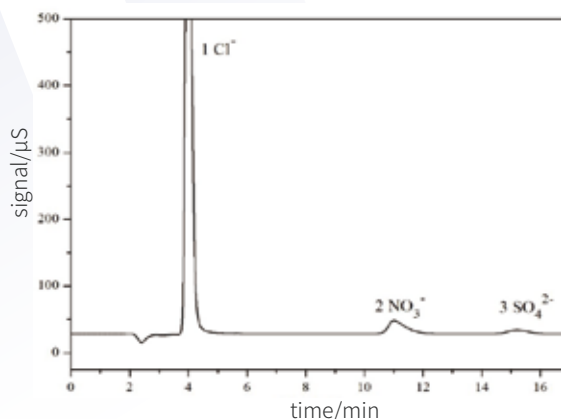

2. Oil analysis

Based on the flammability of petroleum, chlorine, nitrogen and sulfur in petroleum products are converted into hydrides and oxides at high temperature by combustion furnace, then absorbed by alkali liquor. Using CIC-D150 ion chromatograph, SH-AC-3 anion column, 3.6 mM $\text{Na}_2\text{CO}_3 + 4.5 \text{ mM NaHCO}_3$ eluent and bipolar pulse conductance method, under the recommended chromatographic conditions, the chromatogram is as follows.

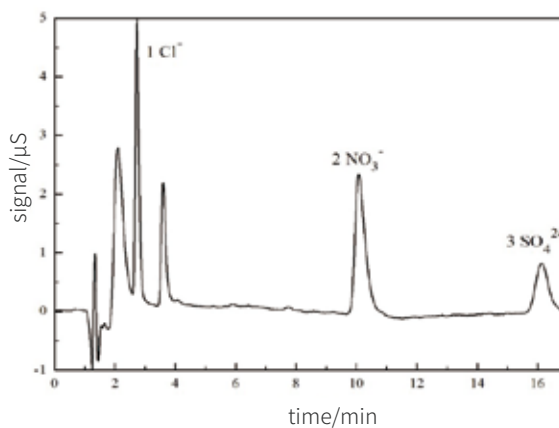

V. Application of Ion Chromatography in Lithium Battery

1. Anions in nickel hydroxide

Nickel hydroxide is the positive active material of Ni based batteries. Ion chromatography can be used to simultaneously detect the impurity anions to provide scientific basis for the production process and performance evaluation of various materials. Using CIC-D180 ion chromatograph, SH-AC-11 anion column and KOH (Gradient Eluent) eluent. Under the recommended chromatographic conditions, the chromatogram is as follows.

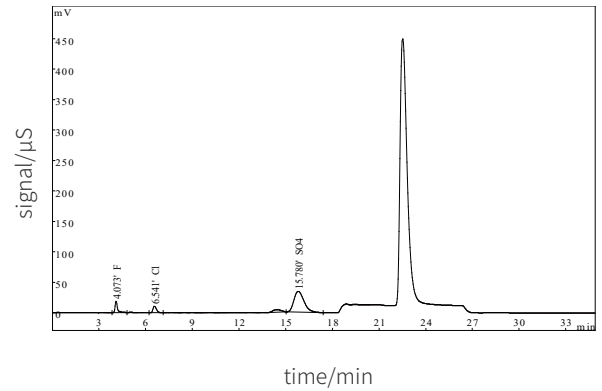

2. Anions in electrolyte

The sample needs to be diluted 1000 times, over 0.22 μ M filter membrane. Using CIC-D180 ion chromatograph, SH-AC-24 anion column and 10 mM KOH Eluent. Under the recommended chromatographic conditions, the chromatogram is as follows.

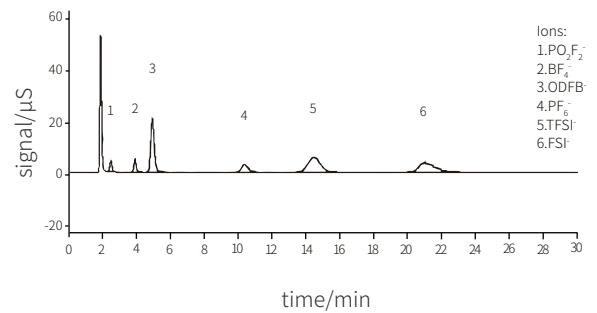

INDUSTRY APPLICATION SOLUTIONS |

VI. Application of Ion Chromatography in Halogen Analysis

Using SH-CIC3000 on-line combustion ion chromatograph, SH-AC-11 anion column and 15 mM KOH Eluent. Under the recommended chromatographic conditions, the chromatogram is as follows.

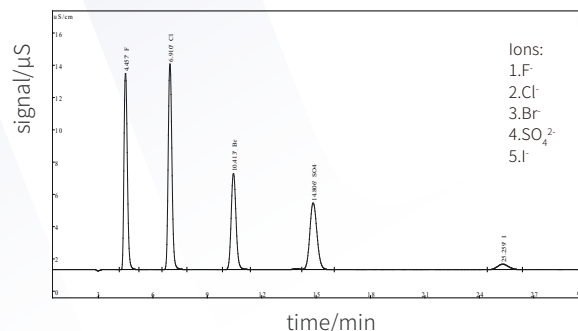

VII. Application of Ion Chromatography in The Analysis of Synthetic Polymer Materials

Using CIC-D150 ion chromatograph, SH-AC-11 anion column, 12 mM KOH (Eluent generator) eluent, under the recommended chromatographic conditions, the chromatogram is as follows. This method is widely used in the determination of anion in circuit boards (IPC-TM-650 2.3.28).

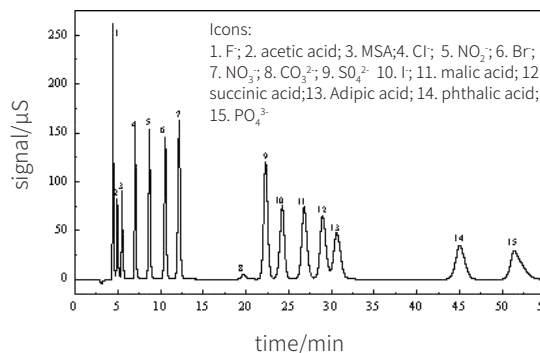

VIII. Application of Ion Chromatography in Public Security Systems Analysis

Explosive analysis

In order to detect chlorate in ammonium nitrate explosive, the soil sample after explosion was extracted by water oscillation, then taking supernatant after centrifugation, filtered by IC-RP column and 0.22 μm microporous filtration membrane. Using CIC-D150 ion chromatograph, SH-AC-12B anion column, 4.0 mM Na₂CO₃ eluent and bipolar pulse conductance method, under the recommended chromatographic conditions, the chromatogram is as follows.

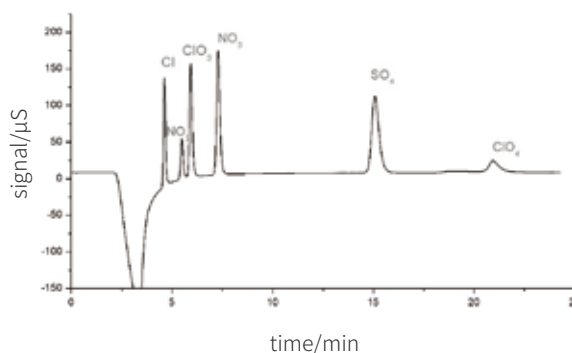

IX. Application of Ion Chromatography in Pharmaceutical Analysis

Antibiotic analysis

In order to determine lincomycin in drugs, samples were extracted by water oscillation, then taking supernatant after centrifuged and filtered by 0.22 microporous membrane. Using CIC-D150 ion chromatograph and SH-AC-3 anion column, 3.6 mM Na₂CO₃+4.5 mM NaHCO₃ eluent and bipolar pulse conductance method, under the recommended chromatographic conditions, the chromatogram is as follows.

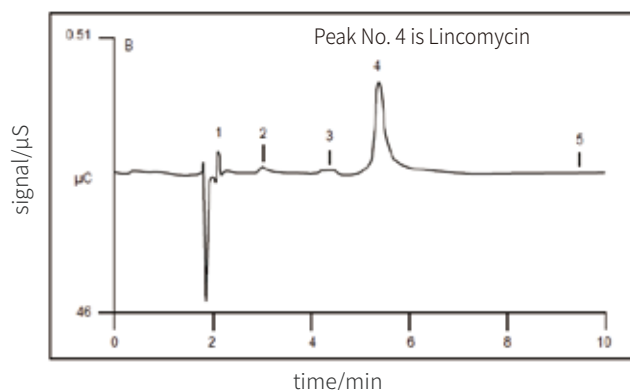

X. Application of Ion Chromatography in Nuclear Power

Anions in boric acid

Using CIC-D300+ ion chromatograph, SH-AP-3 anion column, KOH (Gradient Eluent) eluent and 2000 μL large sample loop. Under the recommended chromatographic conditions, the chromatogram is as follows.

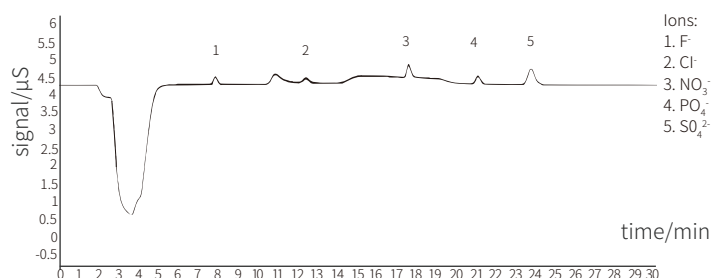

XI. Application of Ion Chromatography in Semiconductor Analysis

Analysis of silicon oxide powder

To detect anions in semiconductor silicon oxide powder, dissolve the sample, pass through a pretreatment column, use CIC-D180 ion chromatograph, anion column, and bipolar pulse conductance method. Under the recommended chromatographic conditions, the obtained chromatogram is as follows.

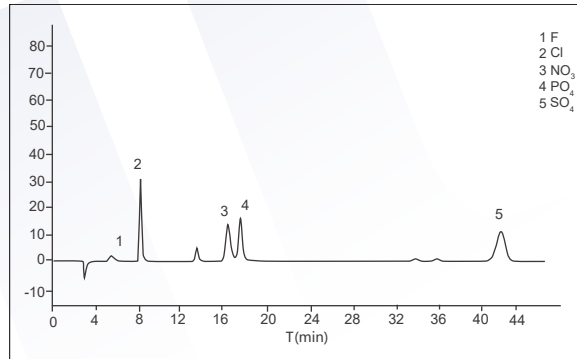

Semiconductor wastewater analysis

Analysis of silicon oxide powder

To detect the content of ethylamine and tetramethylamine in semiconductor wastewater, the samples need to pass through a pretreatment column, use CIC-D180 ion chromatograph, anion column, and bipolar pulse conductance method. Under the recommended chromatographic conditions, the obtained chromatogram was as follows.

